

Loading Dock Solutions



Since 1958, Serco products have been engineered to be the safest and most productive dock equipment in the industry.

 **SERCO**[®]

SAFEFRAME

A SAFER, STRONGER DOCK LEVELER

FOR DECADES all dock levelers installed in a concrete pit have required an installer to place and weld steel shim under the rear frame in order to level the device and provide long-term support. This conventional process can lead to install errors as installers are often working under the dock leveler in a cramped environment and may not use the correct size shim and/or weld the shim properly. The result... the dock leveler can suffer structural fatigue which may lead to expensive repair or replacement.

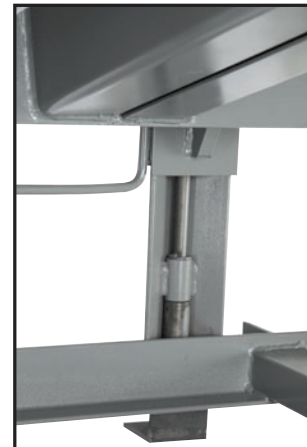
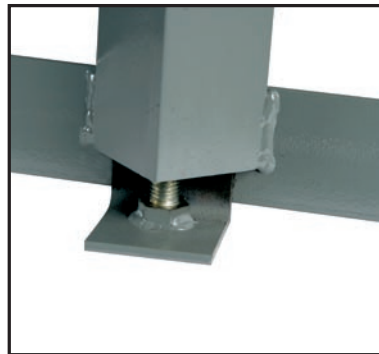

SAFETFRAME ADVANTAGES:

- Greater structural strength & durability
- Eliminates installation issues common with conventional dock levelers
- Ensures level transition from warehouse floor to dock leveler
- Eliminates premature structural fatigue due to improperly shimmed/installed dock leveler



MASTER CONTROL PANEL ▲

- Centralized equipment controls simplify operations
- Interlocks equipment to ensure safe, sequential operation
- Labels can be customized with customer logo's, bilingual information and custom backgrounds



BEFORE

AFTER



SEALS & SHELTERS

SERCO DOCK SEALS AND SHELTERS provide long-lasting solutions to safeguard loading docks against weather-related accidents, escalating energy bills and expensive pilfering. Serco provides dock seal and shelter products to fit every application and budget including these exclusive specialty seals and shelters.

ULTRA SEAL® ▶

- One-piece, diagonal-cut foam construction
- Multi-position internal retention straps
- Patented design insulates like a seal and provides full trailer access like a shelter



◀ ULTRA DOCK SHELTER®

- Withstands off-center trailers without damage
- Roll formed galvanized steel framing
- Creates a tight-seal between the building wall and the back of the truck

GUARDIAN™ HEAD PAD ▶

- Doubles the life of dock seals
- Withstands abusive yard jockey applications
- Only head pad to move vertically with air ride suspensions



◀ SNAPBACK® DOCK SHELTER

- Services a wide variety of trailer sizes and types
- Flexible frame yields to misguided trailers, preventing costly building and shelter damage

DOCK LEVELERS

SERCO DOCK LEVELERS can bring a new level of safety and security to your loading docks. With a comprehensive line of air, hydraulic, mechanical and vertical levelers, Serco has a dock leveler for every need and budget.



◀ W SERIES MECHANICAL DOCK LEVELER ▶

- Pull-Chain activation
- Unlimited float, easy release hold-down
- Easy walkdown
- HYDRA CAM™ design
- **SafeTFrame™** design

AB AIR BAG DOCK LEVELER ▶

- Economical push-button activation
- Virtually maintenance-free
- Automatic lip extension
- **SafeTFrame™** design
- CLEAN FRAME® design
- Optional Reflex™ Anti-Stump-Out safety system



SAFETY PRODUCTS

THE LOADING DOCK is a high-risk area for on-the-job accidents. That's why serco offers a full line of safety products designed to effectively eliminate the dangers of trailer creep, trailer walk, premature departure and empty, open docks.

PITBULL® SAFETY-LOC® POWERED VEHICLE RESTRAINT ▶

- Dual Locking positions at 7" and 11"
- Non-Impact design provides long life
- Low cost of ownership
- 32,000 lbs. of restraining force
- Advanced safe engagement signaling
- Auxiliary power down
- Solid-state controls
- LED interior/exterior communication lights





◀ POWER ASSISTED DOCK LEVELER

- Push-button activation
- Low voltage power-assisted design
- Automatic lip extension
- Manual operation in event of power failure
- **SafeTFrame™** design
- CLEAN FRAME® design
- Optional Dock-Guard™ barrier lip



HFC HYDRAULIC DOCK LEVELER ▶

- Push-button activation
- Full hydraulic operation
- Velocity fuse safety system
- Full control package
- Very low cost of ownership
- **SafeTFrame™** design
- CLEAN FRAME® design
- Optional Dock-Guard™ barrier lip

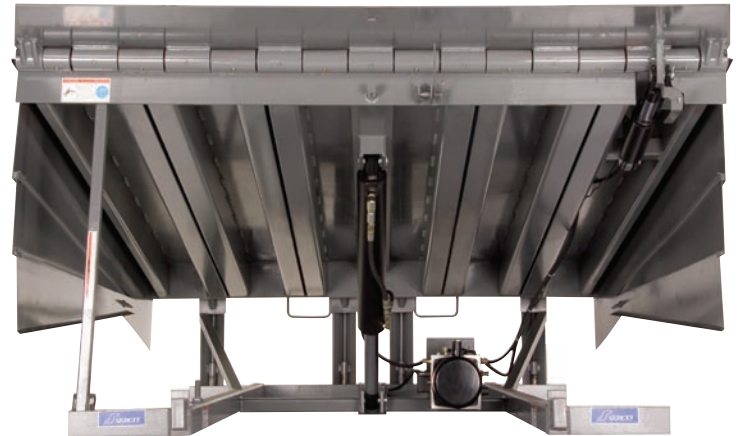

PITBULL® SAFETY-LOC® MECHANICAL VEHICLE RESTRAINT (NOT PICTURED)

- Non-impact, manual operation
- Dual locking positions at 7" and 11"
- 32,000 lbs. of restraining force
- Low maintenance required
- Exterior communication signs



◀ APS-2000 VEHICLE RESTRAINT

- Impact-style design
- Rotating hook engagement
- Patented IP 65 rated motor with non-adjustable electro-mechanical brake

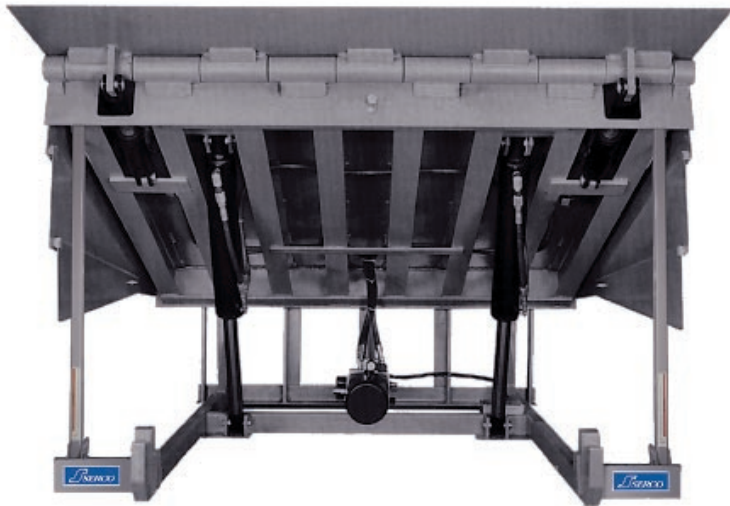

◀ HD HEAVY-DUTY HYDRAULIC DOCK LEVELER

- For the heaviest loading applications
- Reinforced gusseted lip
- I-beam deck structure
- Velocity fuse safety system
- CLEAN FRAME® design
- Optional Dock-Guard™ barrier lip

VERTICAL STORING LEVELER ▶

- Push-button activation
- Stores Vertically in pit or dock shelf
- Helps maintain the ultimate clean work environment
- Ideal for cold storage, food and high-tech applications
- Provides safety, security and energy efficiency at the dock



◀ SAFETY-LOC® SLP RETRACTABLE VEHICLE RESTRAINT

- Push-button activation
- Hydraulically actuated
- Stores under dock leveler, away from ice and debris
- Locking unit floats with trailer movement
- Low maintenance
- Driveway clear for snow removal

SAFETY-CHOCK™ WHEEL RESTRAINT ▶

- Push-button activation
- Driveway mounted
- Secures trailers with lift gates or no rear-impact guard
- Designed for the toughest environments
- Interior/exterior communication system
- Greatest flexibility in wheel restraint





◀ DOCK-GUARD™ BARRIER LIP

- Full-time run-off protection
- Virtually maintenance-free
- Below dock end loading protection
- Smooth transition when lip extended
- 400% stronger than a conventional leveler hinge

VERSASERIES LEVELERS ▶

- 9' wide leveler deck
- Full, unobstructed access for wide loads
- Ultimate dock leveler flexibility
- CLEAN FRAME™ pit design
- Optional Dock-Guard™ barrier lip

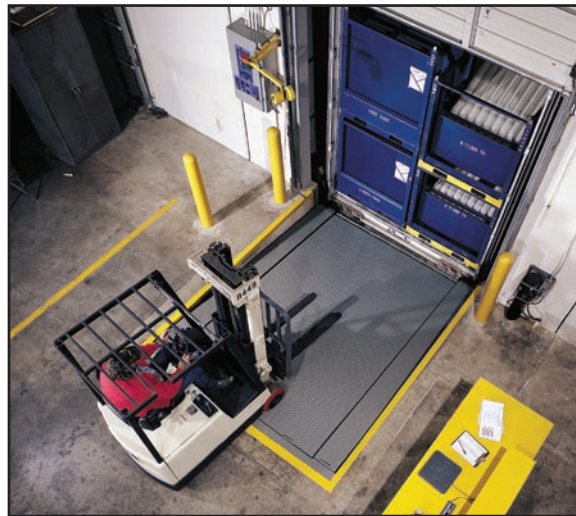

◀ SERCO UNIVERSAL TRUCK-CHOCK™ WHEEL RESTRAINT

- Flush-mounted, in-ground design
- No "lift gate" interference
- No pup trailer interference
- Acts as a guide rail to help trucks back in straight, preventing shelter damage
- Self-contained, remote-mounted power pack
- Constant restraining force to help prevent "trailer creep"
- Electronic components and controls remote-mounted inside dock
- Double acting hydraulic cylinder
- Heater tracer cables to prevent ice build-up

LOADWARRIOR® SPECIALTY LIFT PRODUCTS

SERCO OFFERS A COMPLETE LINE OF LOADWARRIOR hydraulic, air and mechanical lift products to make your workforce more productive and efficient.



◀ LOADWARRIOR TRUCK LEVELER

- Used when dock is too high or low to service trailers with conventional dock levelers
- Safely raises and lowers the trailer to match the height of the loading dock
- Reduces the ramp angle to the back of the trailer
- Available with integral wheel chocking system

LOADWARRIOR HYDRAULIC DOCK LIFT ▶

- Cost- and space-efficient alternative to truck well recesses and concrete ramps
- Accommodates a wide variety of truck styles; from 20" step vans or pick-up trucks, to high cube vans, standard semi trailers and 60" high stake bed trailers
- Flexible mounting option



◀ LOADWARRIOR IN-PLANT SCISSORS LIFT

- Available in 1,500 to 8,000 lbs. capacities
- Solid steel legs with stiffener bars for extra strength and support.
- High pressure cylinders with safety velocity fuses to prevent uncontrolled descent

1612 Hutton Drive, Suite 140
Carrollton, TX 75006

Tel: 1.800.933.4834
Fax: 972.389.4769

Email: sales@sercocompany.com
www.sercocompany.com



A continuing research program is in effect at Serco. We reserve the right to incorporate product improvement at any time without prior notice.